

Toggle Valves

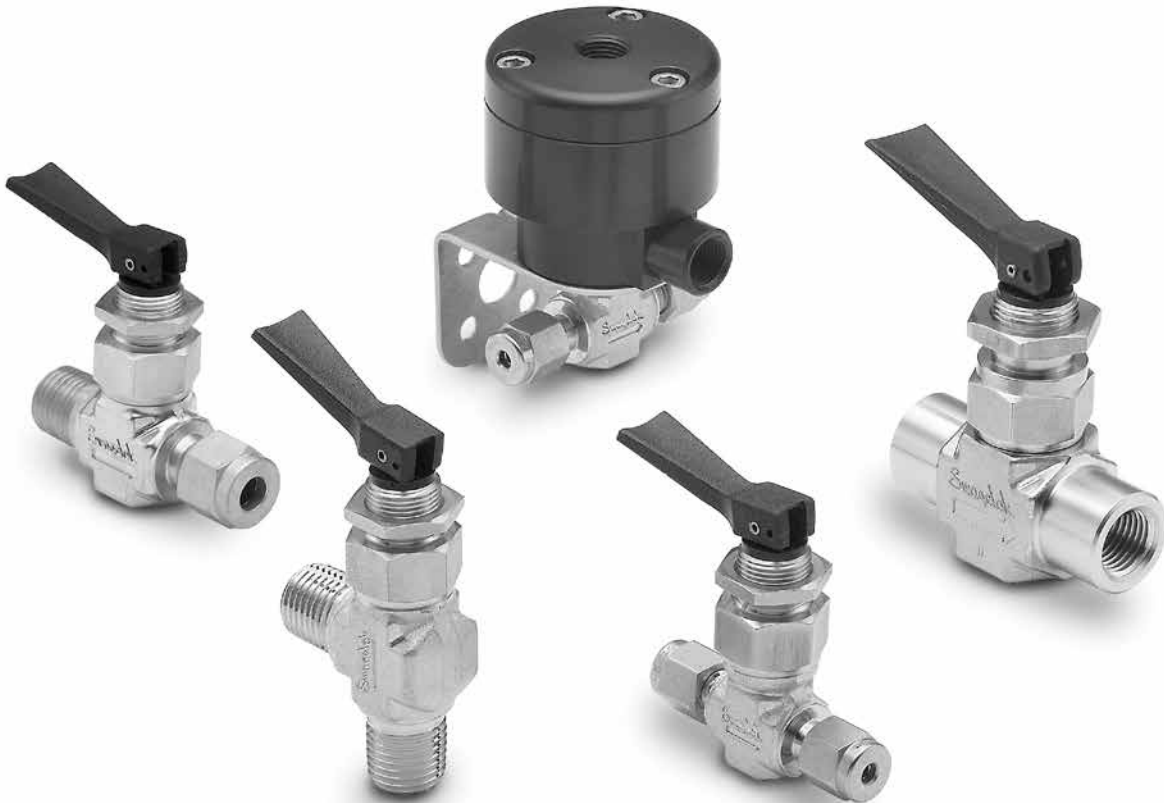

OG, 1G, and 92 Series

- Manual and pneumatically actuated models
- Straight, angle, and cross body patterns
- 316 SS and brass body materials

Features

- Compact, rugged design
- Opens and closes quickly
- Orifice sizes from 0.080 to 0.250 in. (2.0 to 6.4 mm)
- Flow coefficients (C_v) from 0.11 to 0.70
- Straight, angle, and cross flow patterns
- Pneumatic actuation
- Swagelok® tube fitting, female NPT, male NPT, and mixed end connections.

Technical Data

Series	Orifice in. (mm)	Pressure-Temperature Ratings	
		Temperature °F (°C)	Working Pressure psig (bar)
OG	0.080 (2.0)	-20 to 200 (-28 to 93)	300 (20.6)
1G	0.125 (3.2)		200 (13.7)
	0.250 (6.4)		

Ratings based on manual valve. See **Pneumatic Actuators**, page 4, for ratings of valves with pneumatic actuators.

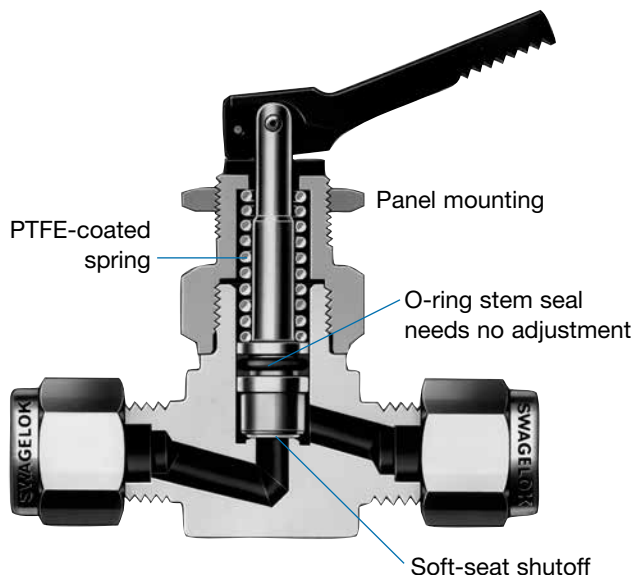

Materials of Construction

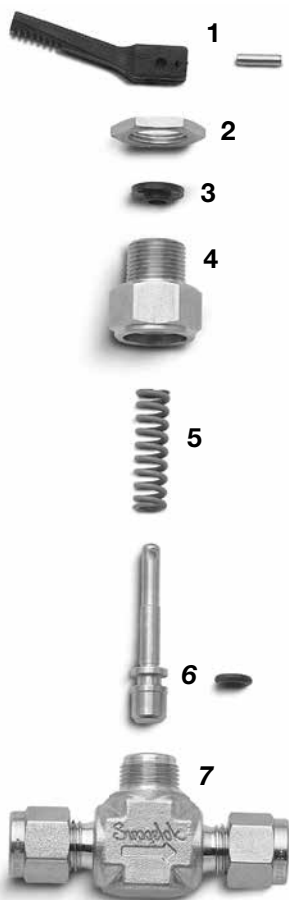

Component	Valve Body Materials	
	316 SS	Brass
	Material Grade/ASTM Specification	
1 Handle	Nylon	
Roll pin	302 SS	
2 Panel nut	Stainless steel	Brass 360/B16
3 Washer	Nylon	
4 Packing nut	316 SS/A276	Brass 360 ^① /B16
5 Spring	PTFE-coated S17700/A313	
6 Stem	316 SS/A276	
O-ring	Fluorocarbon FKM	
Stem tip	PTFE/D1710	
7 Body	316 SS/A182	Brass 377/B283
Nonwetted lubricant	Nickel antiseize in hydrocarbon carrier	
Wetted lubricant	Silicone-based	

Wetted components listed in *italics*.

① Contains a clear nylon thrust washer (not shown) between the packing nut and the spring.

Testing

Every Swagelok toggle valve is factory tested with nitrogen at 200 psig (13.7 bar) at the seat and seal. There is a requirement of no detectable leakage with a liquid leak detector.

Cleaning and Packaging

Every Swagelok toggle valve is cleaned and packaged in accordance with Swagelok *Standard Cleaning and Packaging (SC-10)* catalog, [MS-06-62](#).

Ordering Information and Dimensions

Dimensions, in inches (millimeters), are for reference only and are subject to change.

Stainless Steel Valves

Select an ordering number.

Brass Valves

Replace **SS** with **B**.

Example: **B**-OGS2

Angle-Pattern Valves

Add **-A** to the ordering number.

Example: **SS**-OGS2-**A**

Cross-Pattern Valves

Certain toggle valves are available with cross-pattern bodies, which provide continuous flow between side ports and on-off flow through the bottom port. Contact your authorized Swagelok sales and service representative for more information.

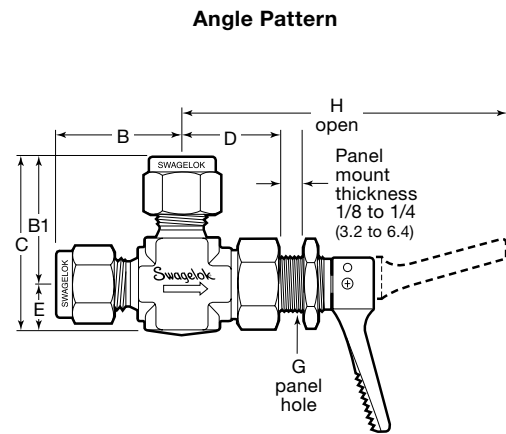
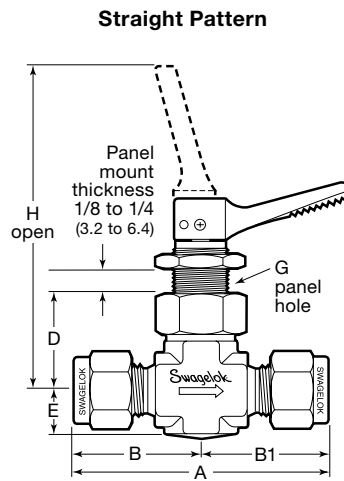

End Connections		C _v	Orifice in. (mm)	Ordering Number	Dimensions, in. (mm)							
Inlet/Outlet	Size				A	B	B1	C	D	E	G	H
Fractional Swagelok tube fittings	1/8 in.	0.11	0.080 (2.0)	SS-OGS2	1.96 (49.8)	0.98 (24.9)		1.29 (32.8)	0.92 (23.4)	0.31 (7.9)	0.53 (13.5)	2.87 (72.9)
	1/4 in.	0.20	0.125 (3.2)	SS-1GS4	2.26 (57.4)	1.13 (28.7)		1.50 (38.1)	0.86 (21.8)	0.38 (9.5)		2.81 (71.4)
	3/8 in.	0.70	0.250 (6.4)	SS-1GS6	2.58 (65.5)	1.29 (32.8)		1.79 (45.5)	1.06 (26.9)	0.50 (12.7)	0.66 (16.8)	3.56 (90.4)
	1/2 in.	0.70	0.250 (6.4)	SS-1GS8	2.80 (71.1)	1.40 (35.6)		1.90 (48.3)				
Metric Swagelok tube fittings	3 mm	0.11	0.080 (2.0)	SS-OGS3MM	1.96 (49.8)	0.98 (24.9)		1.29 (32.8)	0.92 (23.4)	0.31 (7.9)	0.53 (13.5)	2.87 (72.9)
	6 mm	0.20	0.125 (3.2)	SS-1GS6MM	2.26 (57.4)	1.13 (28.7)		1.50 (38.1)	0.86 (21.8)	0.38 (9.5)		2.81 (71.4)
	8 mm	0.20	0.125 (3.2)	SS-1GS8MM	2.22 (56.4)	1.11 (28.2)		1.48 (37.6)	1.06 (26.9)	0.50 (12.7)	0.66 (16.8)	3.56 (90.4)
	10 mm	0.70	0.250 (6.4)	SS-1GS10MM	2.72 (69.1)	1.36 (34.5)		1.86 (47.2)				
	12 mm	0.70	0.250 (6.4)	SS-1GS12MM	2.92 (74.2)	1.46 (37.1)		1.96 (49.8)				
Female NPT	1/8 in.	0.20	0.125 (3.2)	SS-1GF2	1.63 (41.4)	0.81 (20.6)		1.19 (30.2)	0.86 (21.8)	0.38 (9.5)	0.53 (13.5)	2.81 (71.4)
	1/4 in.	0.70	0.250 (6.4)	SS-1GF4	2.12 (53.8)	1.06 (26.9)		1.56 (39.6)	1.06 (26.9)	0.50 (12.7)	0.66 (16.8)	3.56 (90.4)
Male NPT	1/8 in.	0.11	0.080 (2.0)	SS-OGM2	1.50 (38.1)	0.75 (19.0)		1.06 (27.0)	0.92 (23.4)	0.31 (7.9)	0.53 (13.5)	2.87 (72.9)
	1/8 in.	0.20	0.125 (3.2)	SS-1GM2	1.72 (43.7)	0.86 (21.8)		1.23 (31.2)	0.86 (21.8)	0.38 (9.5)		2.81 (71.4)
	1/4 in.	0.20	0.125 (3.2)	SS-1GM4	1.96 (49.8)	0.98 (24.9)		1.36 (34.5)				
	3/8 in.	0.70	0.250 (6.4)	SS-1GM6	2.25 (57.2)	1.12 (28.4)		1.62 (41.1)	1.06 (26.9)	0.50 (12.7)	0.66 (16.8)	3.56 (90.4)
Male NPT/ Swagelok tube fitting	1/8 in.	0.11	0.080 (2.0)	SS-OGM2-S2	1.73 (43.9)	0.75 (19.0)	0.98 (24.9)	1.29 (32.8)	0.92 (23.4)	0.31 (7.9)	0.53 (13.5)	2.87 (72.9)
	1/4 in.	0.20	0.125 (3.2)	SS-1GM4-S4	2.11 (53.6)	0.98 (24.9)	1.13 (28.7)	1.50 (38.1)	0.86 (21.8)	0.38 (9.5)		2.81 (71.4)
Male/female NPT	1/8 in.	0.20	0.125 (3.2)	SS-1GM2-F2	1.63 (41.4)	0.81 (20.6)		1.19 (30.2)	0.86 (21.8)	0.38 (9.5)		2.81 (71.4)

Dimensions shown with Swagelok tube fitting nuts finger-tight.

Pneumatic Actuators

Features

- Valve and actuator are fully assembled and factory tested.
- Positive stem retraction prevents sticking.
- O-ring stem seal requires no packing adjustment.
- Rotatable actuator port allows easy installation.

Actuation Modes

- Normally closed—air opens, spring closes.
- Normally open—air closes, spring opens.
- Double acting—air opens and closes.
- High-pressure normally closed—air opens, spring closes.

Actuator Types

- Standard—valve contains fluorocarbon FKM O-ring, PTFE stem tip, and silicone-based lubricant.
- Low temperature—valve contains Buna C O-ring, PTFE stem tip, and lithium-thickened, silicone-based lubricant.
- High temperature—valve contains fluorocarbon FKM O-ring, PEEK stem tip, and PTFE-based lubricant.
- Nonfluorocarbon—valve contains ethylene propylene O-ring, PEEK stem tip, and silicone-based lubricant.

Technical Data

Actuator Type	Temperature Rating °F (°C)	Valve Working Pressure, psig (bar)		Actuator Pressure Rating psig (bar)
		Normally Open, Double Acting, High-Pressure Normally Closed	Normally Closed	
Standard	-20 to 200 (-28 to 93)	450 (31.0)	300 (20.6)	150 (10.3)
Low temperature	-65 to 200 (-53 to 93)			
High temperature	-20 to 400 (-28 to 204)			
Nonfluorocarbon	-20 to 250 (-28 to 121)			



Normally Closed, High-Pressure Normally Closed, and Double Acting

Normally Open

Materials of Construction

Component	Material
Housing	Anodized aluminum
Spring	UNS 17700
External hardware	18-8 SS
O-ring	Fluorocarbon FKM

See page 2 for other materials of construction.

Pneumatic Actuator Performance

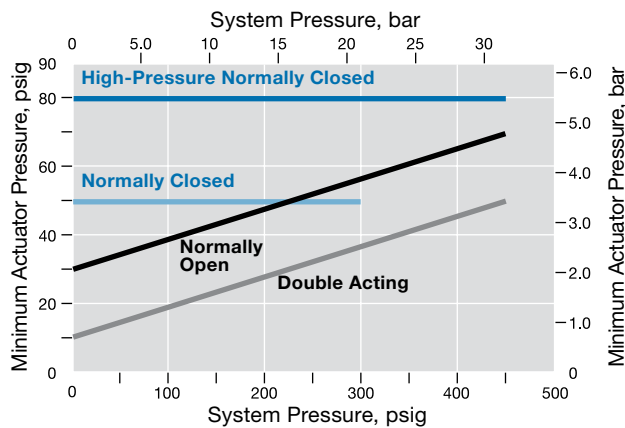

Pneumatic Actuators

Ordering Information and Dimensions

Dimensions, in inches (millimeters), are for reference only and are subject to change.

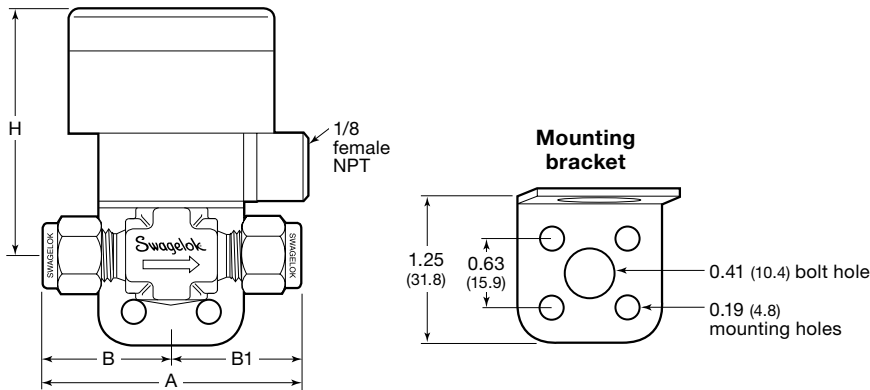

End Connections		C _v	Orifice in. (mm)	Ordering Number	Dimensions, in. (mm)			
Inlet/Outlet	Size				A	B	B1	H
Fractional Swagelok tube fittings	1/8 in.	0.11	0.080 (2.0)	SS-92S2	1.96 (49.8)	0.98 (24.9)		2.21 (56.1)
	1/4 in.	0.20	0.125 (3.2)	SS-92S4	2.26 (57.4)	1.13 (28.7)		2.15 (54.6)
Metric Swagelok tube fittings	6 mm	0.20	0.125 (3.2)	SS-92S6MM	2.26 (57.4)	1.13 (28.7)		
	8 mm	0.20	0.125 (3.2)	SS-92S8MM	2.22 (56.4)	1.11 (28.2)		
Female NPT	1/8 in.	0.20	0.125 (3.2)	SS-92F2	1.63 (41.4)	0.81 (20.6)		2.21 (56.1)
Male NPT	1/8 in.	0.11	0.080 (2.0)	SS-92M2	1.50 (38.1)	0.75 (19.0)		
	1/4 in.	0.20	0.125 (3.2)	SS-92M4	1.96 (49.8)	0.98 (24.9)		2.15 (54.6)
Male NPT/ Swagelok tube fitting	1/8 in.	0.11	0.080 (2.0)	SS-92M2-S2	1.73 (43.9)	0.75 (19.0)	0.98 (24.9)	2.21 (56.1)
	1/4 in.	0.20	0.125 (3.2)	SS-92M4-S4	2.11 (53.6)	0.98 (24.9)	1.13 (28.7)	2.15 (54.6)

Dimensions shown with Swagelok tube fitting nuts finger-tight.

Standard Actuators with Stainless Steel Valves

Add an actuation mode designator to the ordering number.

Actuation Mode	Designator
Normally closed	-C
High-pressure normally closed	-HPC
Normally open	-O
Double acting	-D

Example: SS-92S2-C

Other Actuator Types

For a low-temperature, high-temperature, or nonfluorocarbon actuator, add an actuator designator to the ordering number.

Actuator Type	Designator
Low temperature	-LT
High temperature	-HT
Nonfluorocarbon	-NF

Example: SS-92S2-C-LT

Actuators with Brass Valves

Replace **SS** with **B**.

Example: **B**-92S2-C

Actuators with Angle-Pattern Valves

Insert **-A** into the ordering number.

Example: SS-92S2-A-C

Valves Without Mounting Brackets

Standard actuator assembly includes a mounting bracket.

Removal of the mounting bracket shortens actuator stroke and prevents valve actuation. If the mounting bracket is not used, a spacer washer is required.

To order, add **-W** to the ordering number.

Example: SS-92S2-C-W

Options and Accessories

Optional O-Ring Materials

Fluorocarbon FKM O-rings are standard. For other O-ring materials, add a designator to the valve ordering number.

O-Ring Material	Designator
Buna C	-BC
Buna N	-B
Ethylene propylene	-E
Kalrez®	-KZ
Silicone	-SI

Examples:

SS-OGS2-**BC**

SS-92S2-C-**BC**

In pneumatically actuated valves, only the stem tip O-ring is changed to the optional material.

O-Ring Kits

O-ring kits contain fluorocarbon FKM O-ring, lubricant, and instructions. Select a kit ordering number.

Valve Series	Orifice in. (mm)	O-Ring Kit Ordering Number
OG	0.080 (2.0)	VA70-9K-008
1G	0.125 (3.2)	
		0.250 (6.4)

Handles

Black nylon handles are standard. For other handles, add a designator to the valve ordering number.

Example: SS-OGS2-**BL**

Handle Kits

Handle kits contain black nylon handle and roll pin. For nylon handles of other colors, replace **-BK** with a nylon handle color designator.

Example: NY-5K-14G-**BL**

For a black aluminum handle, replace **NY** with **A**.

Example: **A**-5K-14G-BK

For a stainless steel handle, use ordering number **SS-5S-14G** for a 0.080 in. (2.0 mm) or 0.125 in. (3.2 mm) orifice size and ordering number **SS-5S-16G** for a 0.250 in. (6.4 mm) orifice size.

Handle	Designator
Blue nylon	-BL
Green nylon	-GR
Orange nylon	-OG
Red nylon	-RD
Yellow nylon	-YW
Black urethane-painted aluminum (OG and 1G [0.125 in. orifice])	-BKB
Black anodized aluminum (1G [0.250 in. orifice])	-BKB
316 SS	-SH

Valve Series	Orifice in. (mm)	Handle Kit Ordering Number
OG	0.080 (2.0)	NY-5K-14G-BK
1G	0.125 (3.2)	
		0.250 (6.4)

Handle Positioner

The handle positioner enables setting a valve handle in a desired position and prevents it from rotating—for example, in panel mounting applications where all handles must point in the same direction.

To order, add **-TGP** to the valve ordering number.

Example: SS-OGS2-**TGP**



Handle Positioner Kits

Kits include handle positioner, panel nut, and instructions. Select a handle positioner kit ordering number.

Valve Series	Orifice in. (mm)	Positioner Kit Ordering Numbers	
		316 SS Valves	Brass Valves
OG	0.080 (2.0)	SS-5K-14G	B-5K-14G
1G	0.125 (3.2)		
		0.250 (6.4)	SS-5K-16G

Spring-Return Pin

The spring-return pin stops the valve from being left in the open position.

To order, add **-SPR** to the valve ordering number.

Example: SS-OGS2-**SPR**

Low-Temperature Service

Manual valves with Buna C O-rings, aluminum handles, and lithium-thickened, silicone-based lubricant are available for low-temperature service from -65 to 200°F (-53 to 93°C).

To order, add **-LT** to the valve ordering number.

Example: SS-OGS2-**LT**

Introduction

Since 1947, Swagelok has designed, developed, and manufactured high-quality, general-purpose and specialty fluid system products to meet the evolving needs of global industries. Our focus is on understanding our customers' needs, finding timely solutions, and adding value with our products and services.

We are pleased to provide this global edition of the book-bound *Swagelok Product Catalog*, which compiles more than 100 separate product catalogs, technical bulletins, and reference documents into one convenient, easy-to-use volume. Each product catalog is up to date at the time of printing, with its revision number shown on the last page of the individual catalog. Subsequent revisions will supersede the printed version and will be posted on the Swagelok website and in the Swagelok electronic Desktop Technical Reference (eDTR) tool.

For more information, visit your Swagelok website or contact your authorized Swagelok sales and service representative.

Warranty Information

Swagelok products are backed by The Swagelok Limited Lifetime Warranty. For a copy, visit swagelok.com or contact your authorized Swagelok representative.

Safe Product Selection

When selecting a product, the total system design must be considered to ensure safe, trouble-free performance. Function, material compatibility, adequate ratings, proper installation, operation, and maintenance are the responsibilities of the system designer and user.

WARNING

Do not mix/interchange Swagelok products or components not governed by industrial design standards, including Swagelok tube fitting end connections, with those of other manufacturers.

Not all trademarks listed below apply to this catalog.
Swagelok, Cajon, Ferrule-Pak, Goop, Hinging-Colleting, IGC, Kenmac, Micro-Fit, Nupro, Snoop, Sno-Trik, SWAK, VCO, VCR, Ultra-Torr, Whitey—TM Swagelok Company
15-7 PH—TM AK Steel Corp.
AccuTrak, Beacon, Westlock—TM Tyco International Services
Atlas—TM Asahi Glass Co., Ltd.
ASCO, El-O-Matic—TM Emerson
AutoCAD—TM Autodesk, Inc.
CSA—TM Canadian Standards Association
Crastin, DuPont, Kalrez, Krytox, Teflon, Viton—TM E.I. duPont Nemours and Company
DeviceNet—TM ODVA
Dyneon, Elgiloy, TFM—TM Dyneon
Elgiloy—TM Elgiloy Specialty Metals
FM—TM FM Global
Grafoil—TM GrafTech International Holdings, Inc.
Honeywell, MICRO SWITCH—TM Honeywell
MAC—TM MAC Valves
Microsoft, Windows—TM Microsoft Corp.
NACE—TM NACE International
PH 15-7 Mo, 17-7 PH—TM AK Steel Corp
picofast—Hans Turck KG
Pillar—TM Nippon Pillar Packing Company, Ltd.
Raychem—TM Tyco Electronics Corp.
Sandvik, SAF 2507—TM Sandvik AB
Simriz—TM Freudenberg-NOK
SolidWorks—TM SolidWorks Corporation
UL—Underwriters Laboratories Inc.
Xylan—TM Whitford Corporation
© 2021 Swagelok Company